

# MUSB-5B-SD3-x-S175

鍍層厚度：

Blank : 1u"
2 : 15u"
3 : 30u"

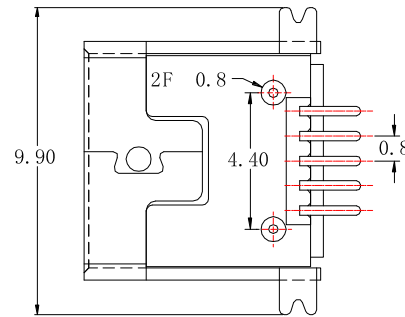
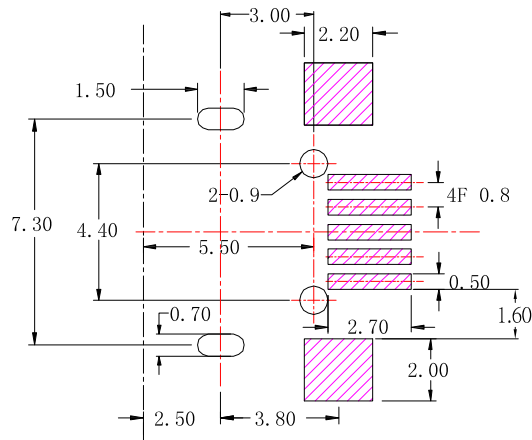
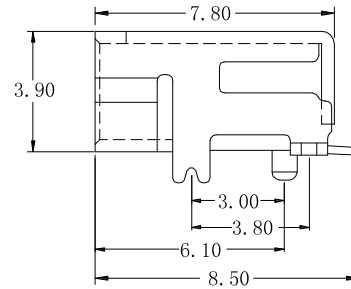
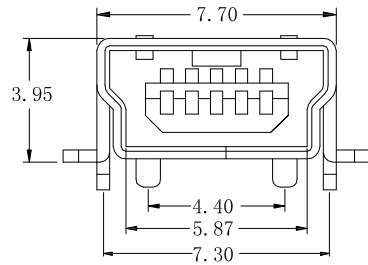
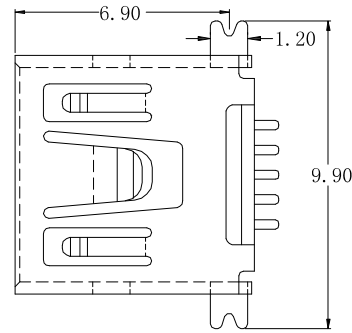

## SPECIFICATIONS

### Electrical :

- 1.Current Rating : 1.0A / contact terminal
- 2.Voltage Rating : 30V DC
- 3.Contact Resistance : 50 mΩ Max
- 4.Dielectric Withstanding Voltage : 300V AC
- 5.Insulation Resistance : 100 MΩ Min

### Material :

- 1.Housing : LCP,UL 94V-0, Black
- 2.Contact : PHOSPHOR BRONZE
- 3.Shell : BRASS

### Finish :

- 1.Contact : Plated Gold in Mating Area ;  
Gold Plated on Solder Balls ;  
Nickel under plated overall
- 2.Shell : Nickel under Plated surface layer

P.C.B LAYOUT MOUNTING PATTERN



TOLERANCE UNLESS OTHERWISE STATED :  
Up to 5 ±0.2  
Above 5 ~ 15 ±0.3  
Above 15 ~ 30 ±0.4  
Above 30 ~ 50 ±0.5  
Angle ±0.3

3RD. ANGEL'S



UNITS MM

DRAWN BY:	DATE
Jack Lu	03/12/18
CHECKED BY:	DATE
Jacky Chen	03/12/18
APPROVED BY:	DATE
Tony Kao	03/12/18

MAT'L		TITLE	CONNECTOR
FINISH		MODLE	MINI USB B TYPE SMT (SHELL : 前DIP後SMT)
SCALE	1 : 1	DWG NO.	MUSB-5B-SD3-x-S175
SHEET NO.	1 of 1	PART NO.	MUSB-5B-SD3-x-S175
		SIZE	A4
		VER	R1

ITEM NO.	DESCRIPTION	DRAWN	DATE
1	新增PCB LAYOUT尺寸	Jack	031218